

General Description

- The FD128 series is a direct PWM drive IC with single-phase and bipolar drive. The IC is suitable for variable speed control Fan of PC.

Features

- Single-phase coil driver, applied to fan or motor.
- Lock function built-in and a lock detect output signal (RD).
- Thermistor or PWM modes are available for speed control.
- An external capacitor (CO) is necessary for lock function.
- An external capacitor (CP = 47pf) for internal 25KHz saw-tooth wave
- Thermal Shutdown built-in.
- Hall IC input (INN) can use as rotation output (FG)
- Internal minimum speed

Function Block Diagram

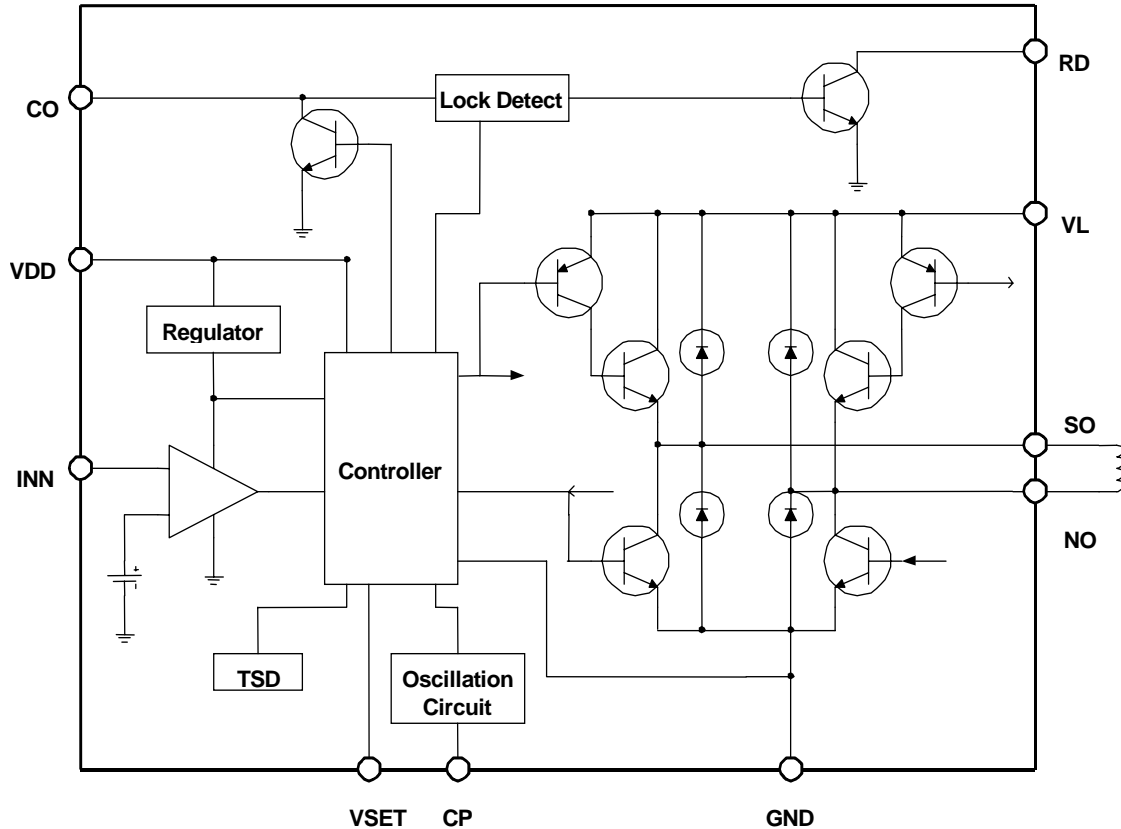

This datasheet contains new product information. Feeling Technology reserves the rights to modify the product specification without notice. No liability is assumed as a result of the use of this product. No rights under any patent accompany the sales of the product.

Pin Assignment

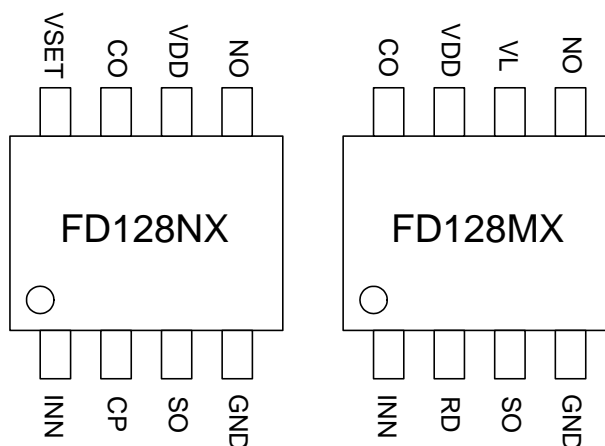

Absolute Maximum Ratings

| Parameter | Symbol | Condition | Rating | Unit |
|---------------------------|-------------------|--------------------|------------|------|
| Supply Voltage | VCCmax | | 20 | V |
| Output Current | IOUTmax | | 1.0 | A |
| Output Supply Voltage | VOUTmax | | 20 | V |
| VSET input Range | VSETmax | Vcc-1.0V | 19 | V |
| RD output supply voltage | VRD | | 20 | V |
| RD output current | IRDmax | | 20 | mA |
| Maximum power dissipation | Pdmax | For exposed pad | 1.1 | W |
| Output continuous current | I _{con} | | 500 | mA |
| Output lock current | I _{ck} | | 900 | mA |
| Output Peak current | I _{Peak} | <100us | 1000 | mA |
| Thermal shutdown protect | Tsd | Chip inner thermal | >150 | °C |
| Operating Temperature | T _{opr} | | -20 to 125 | °C |
| Storage Temperature | T _{stg} | | 150 | °C |

Recommended operating condition at Ta=25°C

| Parameter | Symbol | Conditions | Rating | Unit |
|------------------|--------|------------|--------------|------|
| Supply Voltage | VCC | | 4.5 to 20 | V |
| VSET input range | VSET | | 0 to VCC-1.0 | V |
| INN input Range | INN | | 0 to VCC | V |

This datasheet contains new product information. Feeling Technology reserves the rights to modify the product specification without notice. No liability is assumed as a result of the use of this product. No rights under any patent accompany the sales of the product.

Electrical Characteristics at Ta=25 °C ; Vcc=12V

| Parameter | Symbol | Conditions | Min | Typ | Max | Unit |
|--------------------------------------|-----------------------------------|-----------------------|-----|-----|-----|------|
| Operating Current | I _{CC1} | Rotation mode | | 20 | | mA |
| | I _{CC2} | Lock mode | | 12 | | mA |
| CO pin high level | V _{COH} | | | 3.9 | | V |
| CO pin low level | V _{COL} | | | 1.0 | | V |
| CO charge current I1 | I _{COC1} | V _{CO} =0.5V | | 22 | | uA |
| CO charge current I2 | I _{COC2} | V _{CO} =1.0V | | 35 | | uA |
| CO discharge current | I _{COD} | V _{CO} =4V | | 1.6 | | uA |
| CO lock voltage | V _{COK} | | | 3.6 | | V |
| OFF/ON ratio | T _{off} /T _{on} | | | 10 | | |
| Output lower side saturation voltage | V _{OL} | I _O =200mA | | 0.2 | | V |
| Output upper side saturation voltage | V _{OH} | I _O =200mA | | 0.9 | | V |
| RD pin low voltage | V _{RDL} | I _{RD} =5mA | | 0.2 | | V |
| RD pin leakage current | I _{RDL} | V _{RD} =12 | | | 10 | uA |
| INN pin high voltage | I _{NH} | | 2.4 | | | V |
| INN pin low voltage | I _{NL} | | | | 0.8 | V |
| CP pin high level | V _{CPH} | | | 3.9 | | V |
| CP pin low level | V _{CPL} | | | 1.8 | | V |
| CP charge current | I _{CPOC} | V _{CO} =0.5V | | 8.3 | | uA |
| CP discharge current | I _{CPD} | V _{CO} =4V | | 8.3 | | uA |
| Start-up Voltage | V _{st} | | 3.5 | | | V |
| Minimum Speed | | | | 15 | | % |

Vset voltage level vs. Motor speed(RPM)

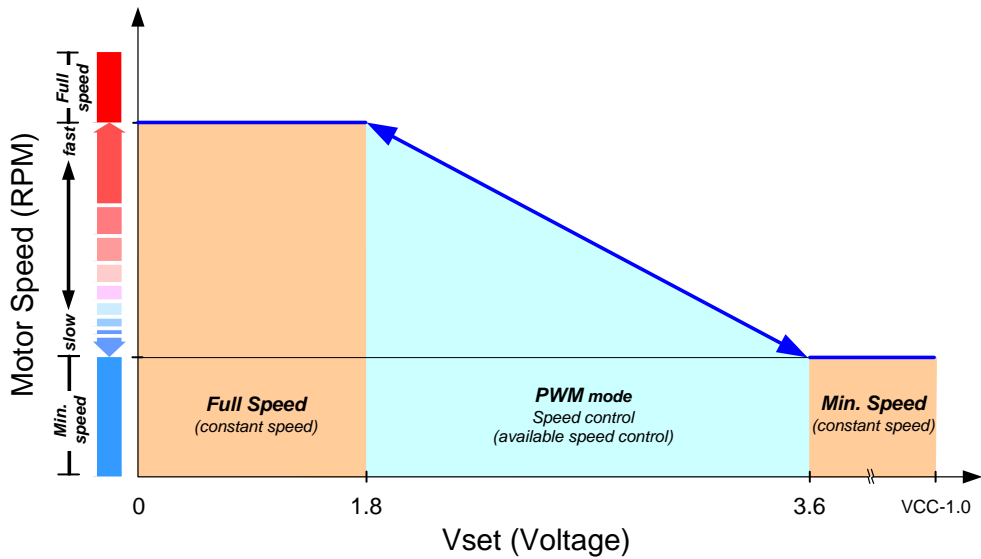

Motor Speed vs. CP pin connect PWM signal operating Duty Cycle

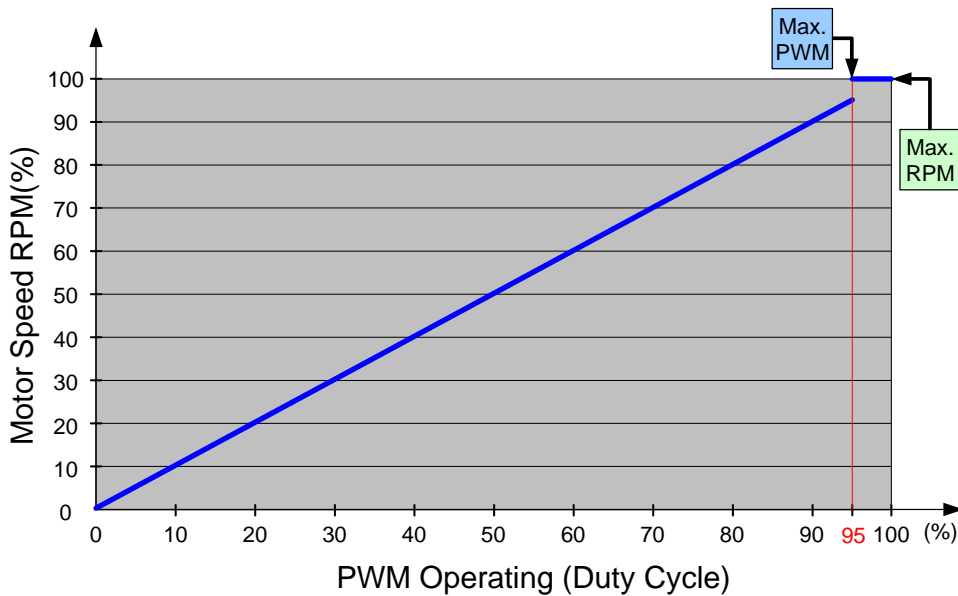

This datasheet contains new product information. Feeling Technology reserves the rights to modify the product specification without notice. No liability is assumed as a result of the use of this product. No rights under any patent accompany the sales of the product.

Motor Speed vs. Vset pin connect PWM signal Operating Duty cycle

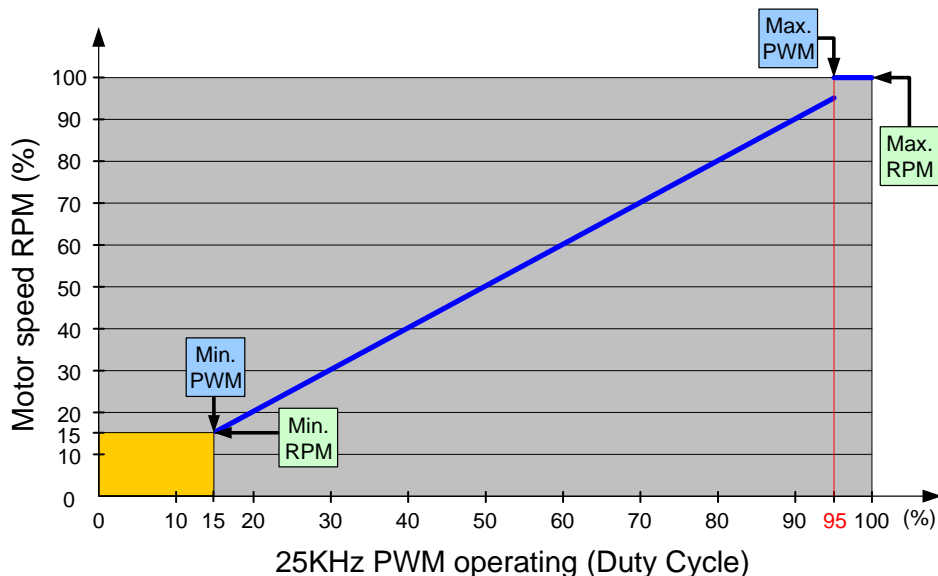

Two kinds use the outside PWM signal to control the difference of way of rotational speed of the fan to prove: :

1. Input PWM signal by Vset pin

The slowest rotational speed is limited, it is unable to totally stop operating.

2. Input PWM signal by CP pin

The slowest rotational speed is not limited , can totally stop operating

Note: Circuit of using that please watch the application circuits.

Truth Table

| INN | CP | CO | NO | SO | FG | RD | Mode |
|-----|----|---------|-----|-----|-----|-----|----------------|
| H | H | Un-lock | L | H | OFF | L | Rotation |
| L | | | H | L | L | L | |
| H | L | Un-lock | L | OFF | OFF | L | Re-circulation |
| L | | | OFF | L | L | L | |
| H | | Lock | OFF | H | OFF | OFF | Lock Protect |
| L | | | H | OFF | L | OFF | |

Note: CP-H = CP > VSET, CP-L = CP < VSET

This datasheet contains new product information. Feeling Technology reserves the rights to modify the product specification without notice. No liability is assumed as a result of the use of this product. No rights under any patent accompany the sales of the product.

Application Notes

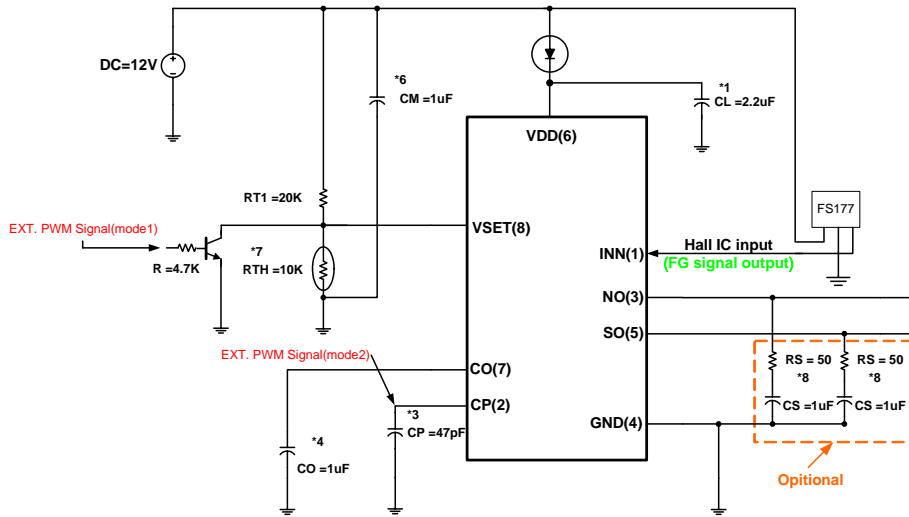

FD128NX Application circuit

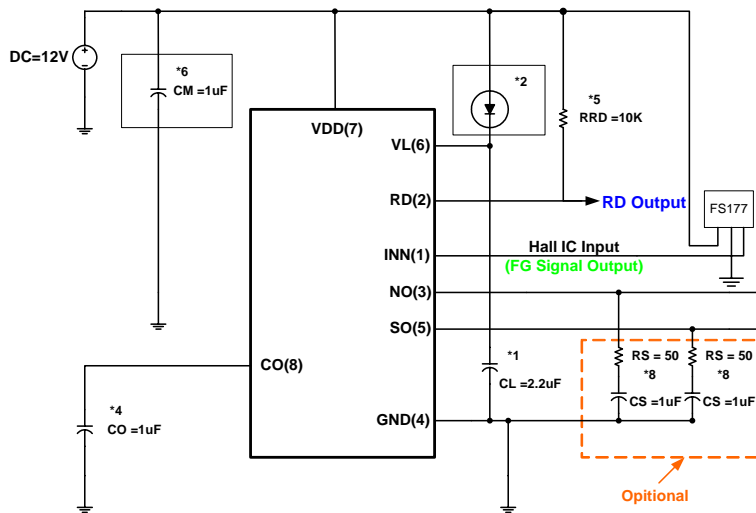

FD128MX Application Circuit

This datasheet contains new product information. Feeling Technology reserves the rights to modify the product specification without notice. No liability is assumed as a result of the use of this product. No rights under any patent accompany the sales of the product.

***1 Recirculation Capacitance**

CL (2.2uF) capacitor is for PWM drive and kick back absorption, especially when the diode used.

***2 Thermal Dissipation Handle Diode**

To decrease the Output Transistor Voltage drop, then improve the thermal handle capability.

***3 PWM Oscillator frequency setting capacitor**

Setting the CP = 47pF to get the 25KHz PWM frequency.

***4 Lock shutdown time setting capacitor**

CO value decides the time of lock function to turn on or turn off drivers.

***5 Rotation Detect pull-up Resistor**

For RD open collector structure, low for rotation mode and high for lock mode.

***6 VDD stability capacitor**

When the (*1,*2) does not exist, the CM capacitor replace the CL to absorption the VDD spike and work as the re-circulation capacitor.

***7 Thermistor Resistor**

For speed control runs at the PWM mode.

***8 Output overshoot hold RC**

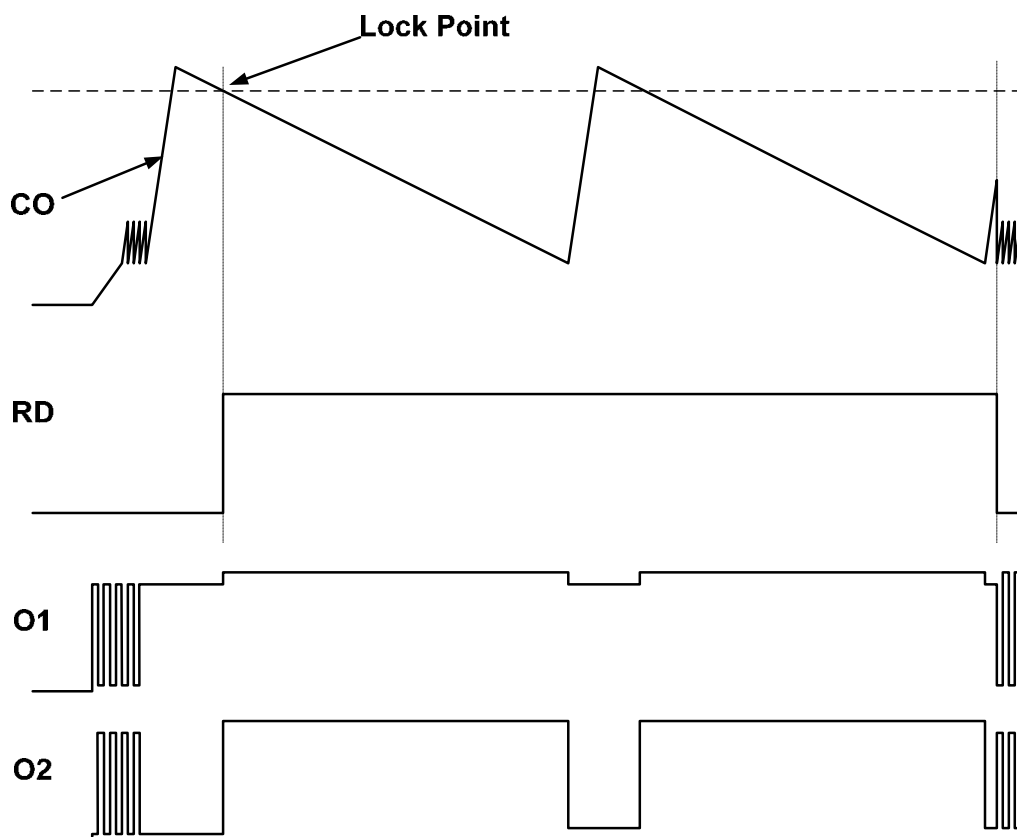

Auto-Shutdown Timing

Function Description

I. Minimum Speed Mode

When VSET voltage larger than the voltage of the internal minimum speed setting voltage (V_{SL}). Then the fan would sustain about 15% duty ratio to make the fan working on lowest speed.

If the VSET is left open, then the fan also enters the minimum speed mode.

II. PWM Control mode(Vset pin connect DC voltage)

When VSET is between V_{SL} and V_{CPL} . Then the output would be turn on at $V_{SET} < V(CP)$ and turn off at $V_{SET} > V(CP)$. The CP frequency decided the Switch Period and the result of VSET compared to $V(CP)$ had the duty ratio.

III. Full Speed Mode

When VSET is lower than V_{CPL} , then the fan would enter the full speed mode.

This datasheet contains new product information. Feeling Technology reserves the rights to modify the product specification without notice. No liability is assumed as a result of the use of this product. No rights under any patent accompany the sales of the product.

IV. Thermistor Mode

The VSET pin can use the Thermistor to produce the thermal control of system, and saving the power around the room temperature.

V. External 25KHZ input control

The signal is suggested to send into CP. The result is similar as that VSET must be left open to use the V_{SL} . So, the input voltage must be over the V_{SL} to turn on drivers.

VI. Lock Mode

When the fan stop and the capacitor (CO) continue to be discharged until the V_{COK} point. Then the fan should enter the lock mode to turn off the low-side drivers. This action would save the power consumption and avoid the over-heating philosophy. It would be released until the V_{COL} point. The rotation detect signal (RD) would set to High at lock mode.

VII. Other

Package Outline

Sop8 : (exposed pad)

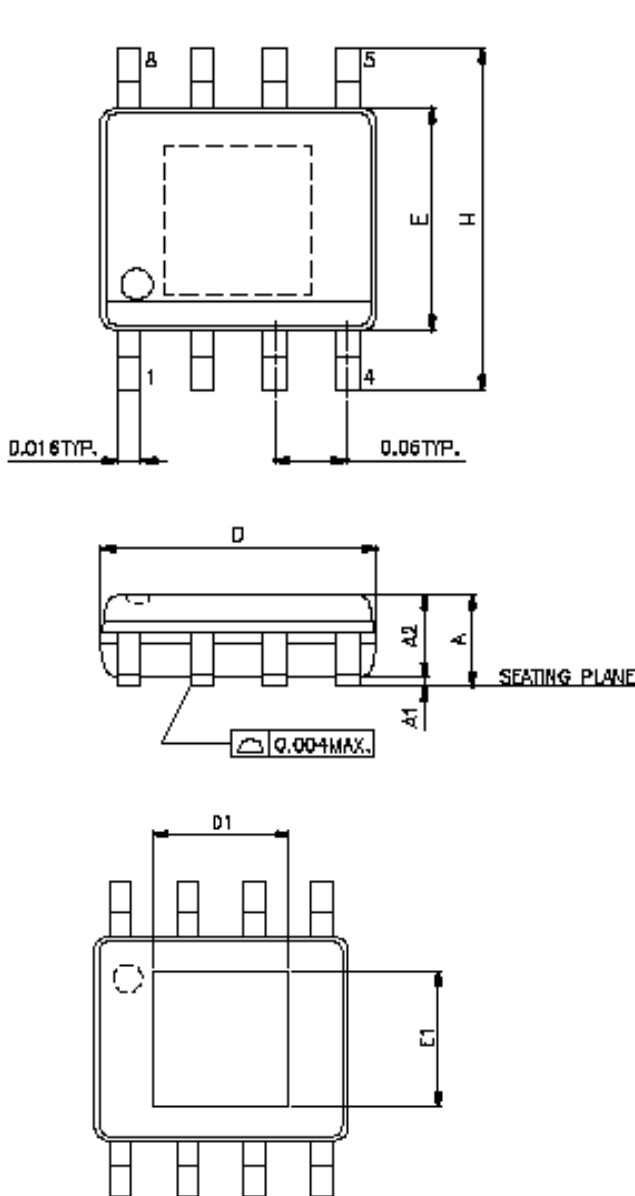

E.P. VERSION ONLY

P.S. Under Exposed pad, the PCB layout rather to be uncovered copper and connected to GND or Floating

| SYMBOLS | MIN. | MAX. |
|----------------|-------|-------|
| A | 0.053 | 0.069 |
| A1 | 0.002 | 0.006 |
| A2 | — | 0.059 |
| D | 0.189 | 0.196 |
| E | 0.150 | 0.157 |
| H | 0.228 | 0.244 |
| L | 0.016 | 0.050 |
| θ° | 0 | 8 |

UNIT : INCH

THERMALLY ENHANCED DIMENSIONS

| PAD SIZE | E1 | D1 |
|----------|-----------|-----------|
| 90X90E | 0.081 REF | 0.081 REF |
| 95X13E | 0.086 REF | 0.117 REF |

UNIT : INCH

NOTES:

1. JEDEC OUTLINE : N/A
2. DIMENSIONS "D" DOES NOT INCLUDE MOLD FLASH, PROTRUSIONS OR GATE BURRS. MOLD FLASH, PROTRUSIONS AND GATE BURRS SHALL NOT EXCEED .15mm (.006in) PER SIDE.
3. DIMENSIONS "E" DOES NOT INCLUDE INTER-LEAD FLASH, OR PROTRUSIONS. INTER-LEAD FLASH AND PROTRUSIONS SHALL NOT EXCEED .25mm (.010in) PER SIDE.

This datasheet contains new product information. Feeling Technology reserves the rights to modify the product specification without notice. No liability is assumed as a result of the use of this product. No rights under any patent accompany the sales of the product.



ORDER INFORMATION

| Part Number | Operating Temperature | Package |
|-------------|-----------------------|-----------|
| FD128MX-LF | -20 °C to +125 °C | SOP8(E.P) |
| FD128NX-LF | -20 °C to +125 °C | SOP8(E.P) |

E.P.: exposed pad

Product Part Number Vs. Function Table

| Part Number | Auto lock- shutdown restart | Thermal- shutdown restart | Rotation- detection (RD) | PWM |
|-------------|--------------------------------|------------------------------|--------------------------------|-----|
| FD128MX-LF | | | | |
| FD128NX-LF | | | | |

This datasheet contains new product information. Feeling Technology reserves the rights to modify the product specification without notice. No liability is assumed as a result of the use of this product. No rights under any patent accompany the sales of the product.